

DESCRIPTION:

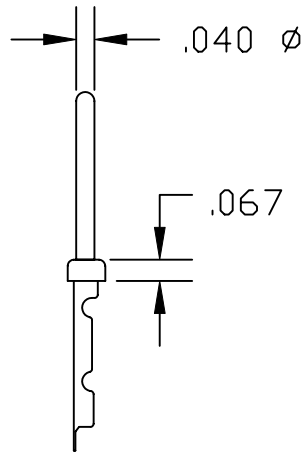
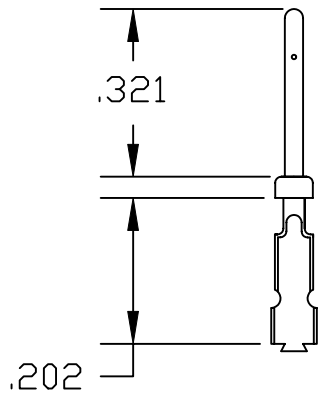

MATERIAL: BRASS

RoHS COMPLIANT

WIRE SIZE: 24 - 28 AWG

NOTE #1: CONTACTS SUPPLIED LOOSE PIECE (500 PER BAG)

NOTE #2: RECOMMENDED MAX. INSULTATION DIAMETER FOR 24-28 IS .035".

WIRE SIZE:

PLATING	24-28
GOLD FLASH ON MATING AREA NICKEL ON WIRE CRIMP	170-101-170L001
.000010" GOLD OVER .000050" NICKEL ENTIRE CONTACT	170-101-170L002
.000030" GOLD OVER .000100" NICKEL ENTIRE CONTACT	170-101-170L003

	THESE DRAWINGS AND SPECIFICATIONS ARE THE PROPERTY OF NorComp AND SHALL NOT BE REPRODUCED, COPIED OR USED AS THE BASIS FOR THE MANUFACTURE OF SALE OF APPARATUS WITHOUT WRITTEN PERMISSION.		DRAWN: PAM JENKINS	DATE: 5-23-02
			CHECKED:	DATE:
NorComp		SCALE:	SHEET 1 OF 1	REV 1
		DWG NO. 170-101-170L00X		